



**MANUAL DE MONTAGEM
ASSEMBLY INSTRUCTIONS
INSTRUCCIONES DE MONTAJE**

COD BR: BST 19

Sumário Summary Resumen

Introdução Introduction Introducción	3
Antes de começar Before starting Antes de comenzar	4
Evite acidentes Avoid accidents Evitar accidentes	4
Dimensões e ferramentas Dimensions and tools Dimensiones y herramientas	5
Identificação das peças Identifying parts Identificación de las piezas	6
Acessórios incluídos na caixa Hardware included in box Accesorios incluidos en la caja	7
Montagem do móvel Furniture assembly Montaje del mueble	8

Introdução Introduction Introducción

Leia atentamente este manual e siga os passos indicados para que o produto não perca a garantia e também para uma perfeita montagem.

Read this manual and follow the steps in order to keep the guarantee and also for the perfect fit.

Lea este manual y siga los pasos para que el producto no pierda la garantía y también para el ajuste perfecto.

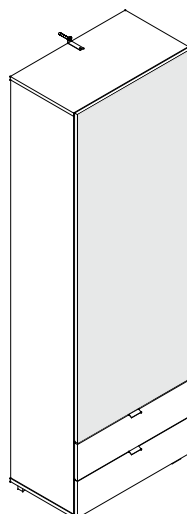

Antes de começar Before starting Antes de comenzar

Antes de começar a montagem prepare o ambiente, deixando-o completamente limpo e com bom espaço para iniciar o trabalho.

Prepare the room before starting the assembly, leaving it completely clean and the area in good condition to start the work.

Antes de comenzar el montaje preparar el ambiente, dejándolo completamente limpio y con bueno espacio para comenzar el trabajo.

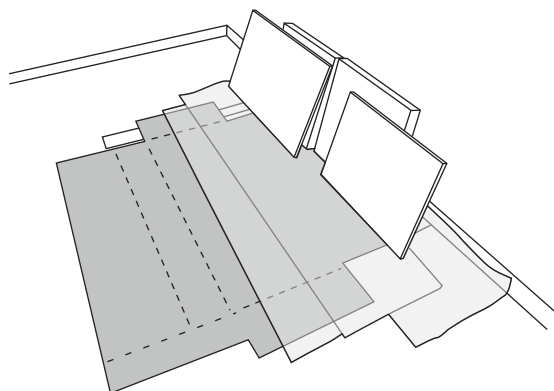

Utilize o papelão da própria embalagem para separar e apoiar as peças retiradas das caixas.

Use the cardboard of the packaging to separate and support the parts removed from the boxes.

Utilice el cartón de la embalaje para separar y apoyar las piezas desmontadas de las cajas.



Forre a área de montagem com um cobertor ou tapete. Assim, você evita avarias nas peças durante o processo de montagem.

Cover the assembly area with a blanket or carpet to avoid damaging the parts during the assembly process.

Cubrir la zona de ensamble con una manta o alfombra. De este modo, se evitan daños en las piezas durante el proceso de montaje.



Evite acidentes Avoid accidents Prevenir accidentes

Solicitamos observar atentamente as orientações de montagem como: fixação do produto na parede, colocação de cola em locais específicos necessários, o peso suportado pelo produto, etc...

We request you to carefully observe the assembly instructions as: fixing the product on the wall, adding glue in needed and specific places, product weight limit, etc.

Pedimos que lea atentamente las instrucciones, principalmente las informaciones de fijación del producto en la pared, colocación de pegamento en local específico y necesario, el peso soportado por el producto etc...

Não escale ou se apoie no móvel.

Do not climb or lean on the furniture.

No se suba ni se apoye en el mueble.

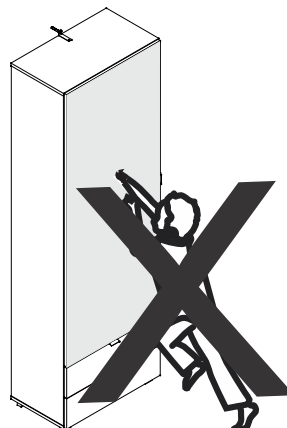

Dimensões e ferramentas
Dimensions and tools
Dimensiones y herramientas

Dimensões:

L: 600 A:1865 P: 345 mm

Dimensions:

W: 23.62 H: 73.42 D: 13.58 inches

Dimensiones:

L: 600 A: 1865 P: 345 mm

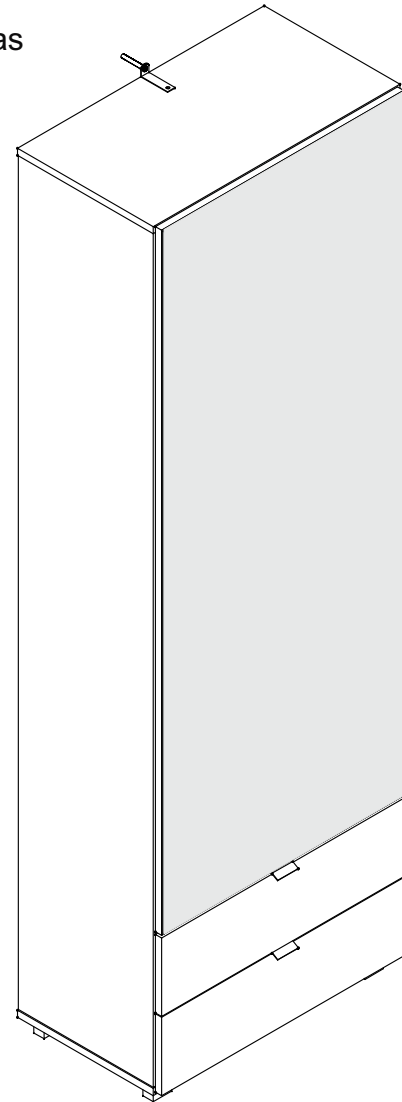

Limpeza
Cleanig
Limpieza

Pano levemente umedecido com água, seguido de pano seco, não utilizar produtos químico ou abrasivos.
Slightly dampened cloth and after a dry cloth, do not use chemicals or abrasives.
Solamente utilizar un paño húmedo y después un paño seco, no utilice productos químicos o abrasivos.

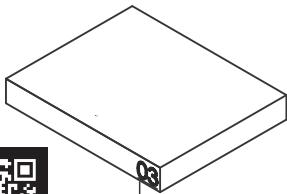

UTILIZE ALCOOL APENAS PARA REMOVER O NUMERO DAS PEÇAS
USE ALCOHOL ONLY TO REMOVE PART NUMBERS
UTILICE ALCOHOL SOLAMENTE PARA ELIMINAR EL NUMERO DE LAS PIEZAS

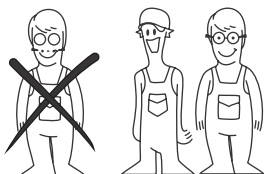

Para facilitar a montagem, utilize uma parafusadeira elétrica.
To improve assembly, use an eletronic screwdriver.
Para facilitar el armado, utilice un destornillador eléctrico.

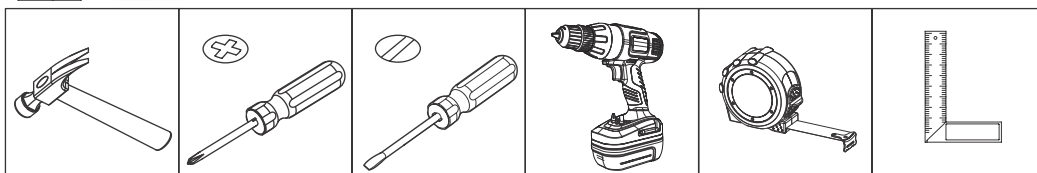

COD BR: BST 19

PEÇA	DESCRIÇÃO	QUANT.
001	BASE	1
002	TAMPO	1
003	LATERAL ESQUERDA	1
004	LATERAL DIREITA	1
005	PRATELEIRA	5
006	PORTA	1
007	FRENTE DE GAVETA	2
009	FUNDO DE GAVETA	2
010	COSTA MAIOR	1
011	COSTA MENOR	5
012	ESPELHO	1
020	LATERAL DE GAVETA DIREITA	2
021	COSTA DE GAVETA	2
022	LATERAL DE GAVETA ESQUERDA	2

PART	DESCRIPTION	QTY
001	BASE	1
002	TOP	1
003	LEFT SIDE	1
004	RIGHT SIDE	1
005	SHELF	5
006	DOOR	1
007	DRAWER'S FRONT	2
009	DRAWER'S BOTTOM	2
010	LONGER BACK	1
011	LOWER BACK	5
012	MIRROR	1
020	DRAWER'S RIGHT SIDE	2
021	DRAWER'S BACK	2
022	DRAWER'S LEFT SIDE	2

PIEZA	DESCRIPCIÓN	CANTIDAD
001	BASE	1
002	TAPA	1
003	LATERAL IZQUIERDA	1
004	LATERAL DERECHA	1
005	REPISA	5
006	PUERTA	1
007	FRENTE CAJÓN	2
009	FONDO CAJÓN	2
010	REVÉS MAYOR	1
011	REVÉS MENOR	5
012	ESPEJO	1
020	LATERAL DERECHA CAJÓN	2
021	REVÉS CAJÓN	2
022	LATERAL IZQUIERDA CAJÓN	2

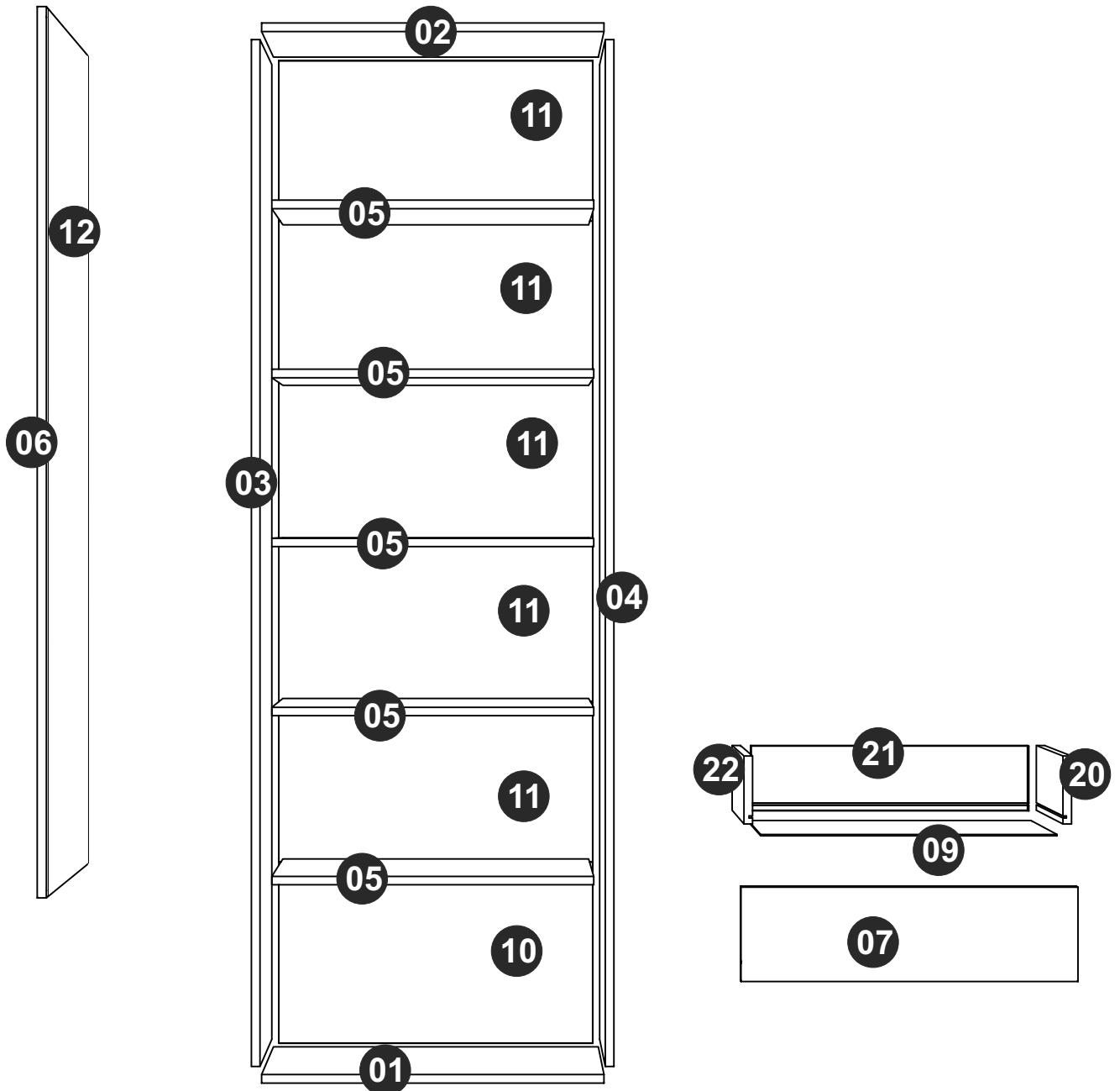



EF 000033 x 44
8X30



EF 000094 x 32



EF 000216 X 32



EF 000106 x 34
3,5X14 CC



EF 000168 X 120
10X10 C/C



EF 000381 x 8
3X25 CC



EF 000132 x 4
4X50 CC



GIZ x 01
CHALK x 01
TIZA x 01

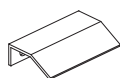

PUXADOR x 3
HANDLE x 3
MANIJA x 3



CORREDIÇA x 4
DRAWER TRAKS x 4
CORREDERAS x 4

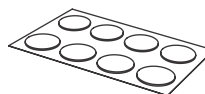

TAPA FUROS x 36
STICKER x 36
TAPAS PLÁSTICAS x 36



EF 000016 X 1

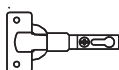

EF 000044 X 3



EF 000024 X 3



PÉS RETÂNGULARES x 4
RETANGULAR FEET x 4
PIES RECTANGULARES x 4



EF 000248 X 1
3,5X14 CP



EF 000246 x 1
5X50 CF

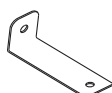

EF 000529 X 1

Utilize para medir as ferragens.

Utilice para medir el herraje.

Use for measuring the hardware.

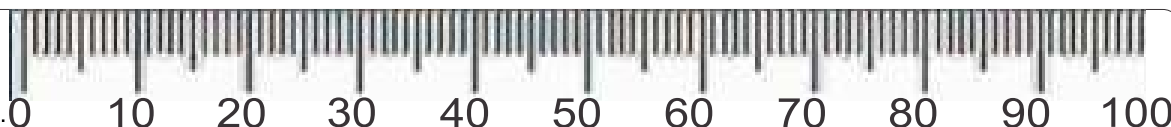

Garantia (exclusivo para o Brasil/exclusivo de Brasil/exclusive to Brazil):

A garantia dos produtos fabricados pela BRV Móveis, abrange eventuais defeitos-vícios de fabricação, no prazo estabelecido pelo código de Defesa do Consumidor, em seu artigo 26.II. o qual prevê a garantia de 90 (noventa) dias.

A = 6KG - 13.22LB

B = 3KG - 6.61LB

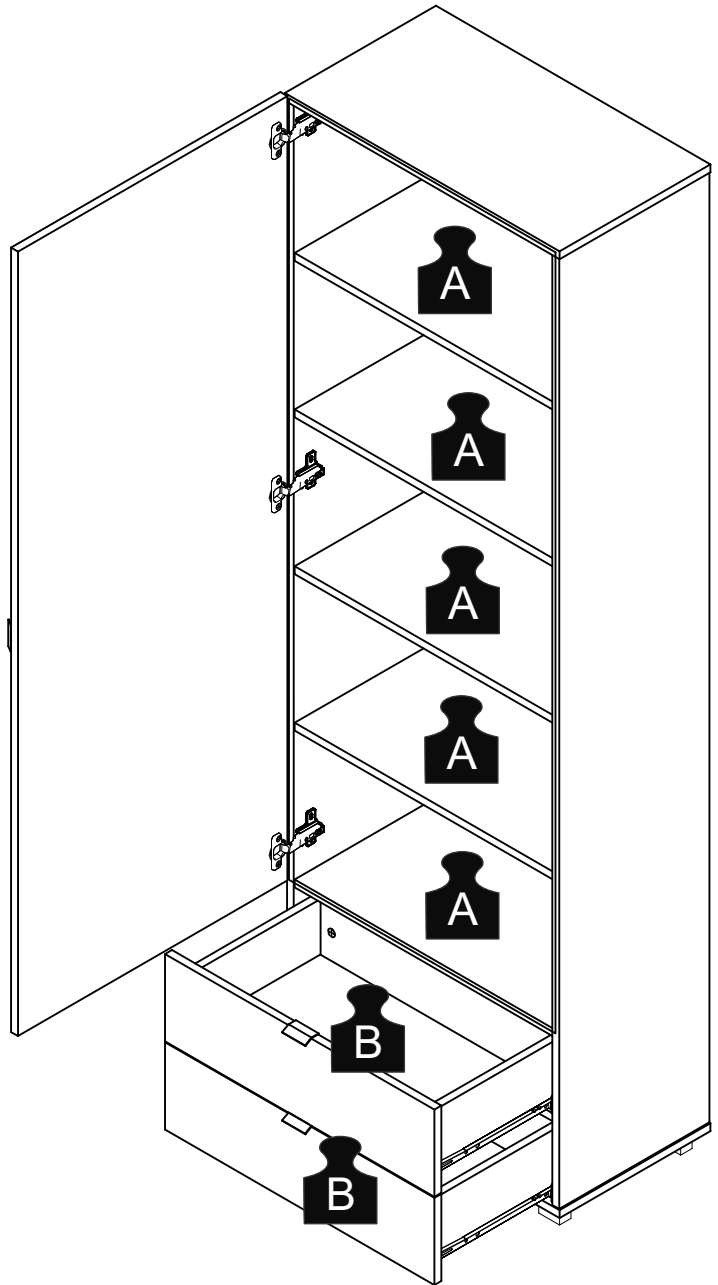

Limite de peso: 15 pares de sapato
Weight limit: 15 pairs of shoes
Límite de peso: 15 pares de zapato

PASSO 1 / STEP 1 / PASO 1

Insira a ferragem EF 000094 nas peças 02, 03, 04, 07, 20 e 22.
Insert hardware EF 000094 into pieces 02, 03, 04, 07, 20 and 22.
Añade el herraje EF 000094 en las piezas 02, 03, 04, 07, 20 y 22.

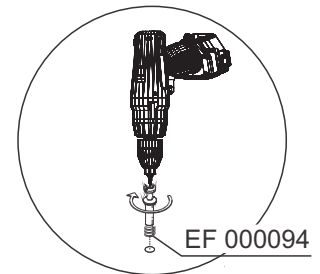
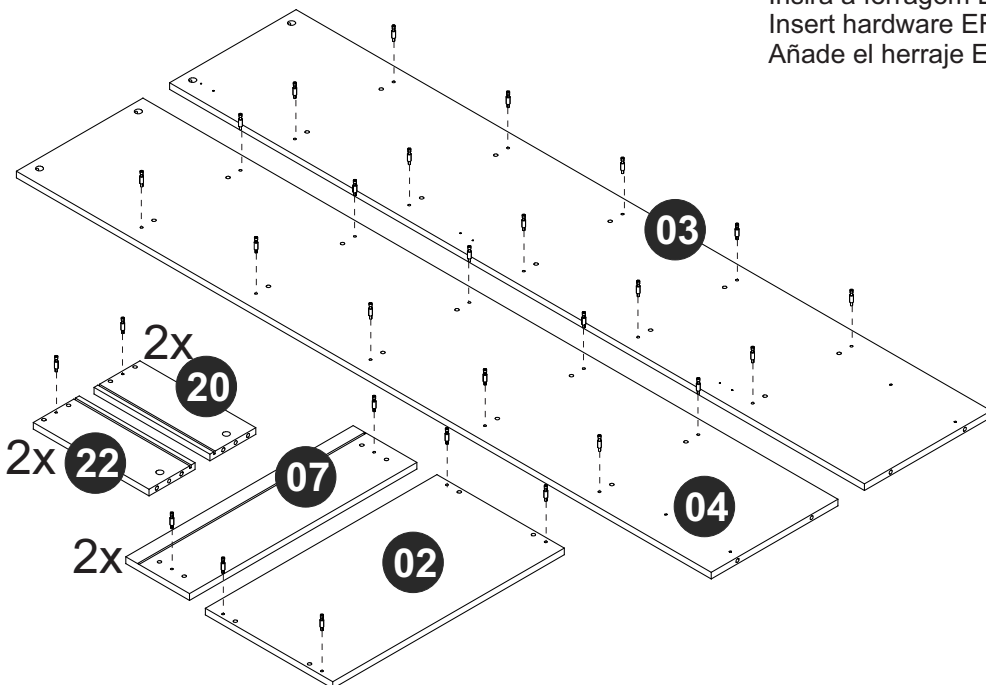

PASSO 2 / STEP 2 / PASO 2

Insira a ferragem EF 000033 nas peças 03 ,04, 05, 20, 21 e 22.
Insert hardware EF 000033 into pieces 03 ,04, 05, 20, 21 and 22.
Añade el herraje EF 000033 en las piezas 03 ,04, 05, 20, 21 y 22.

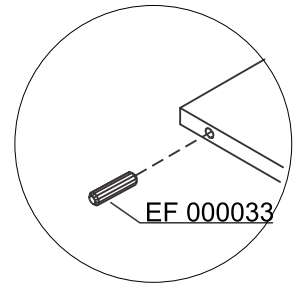
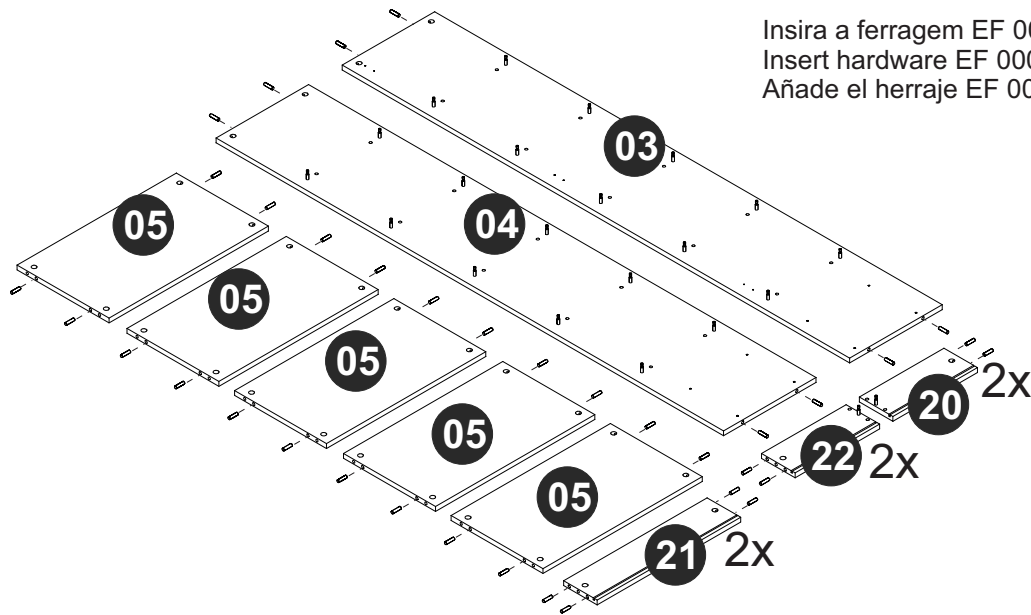

PASSO 3 / STEP 3 / PASO 3

Fixe a ferragem EF 000024 usando a ferragem EF 000106 na peça 03.
Fixe as corredeiras utilizando a ferragem EF 000106 nas peças 03 e 04.
Fix hardware EF 000024 using hardware EF 000106 into piece 03.
Attach the drawer tracks using hardware EF 000106 into pieces 03 and 04.
Fije el herraje EF 000024 utilizando el herraje EF 000106 en la pieza 03.
Fije las correderas utilizando el herraje EF 000106 en las piezas 03 y 04.

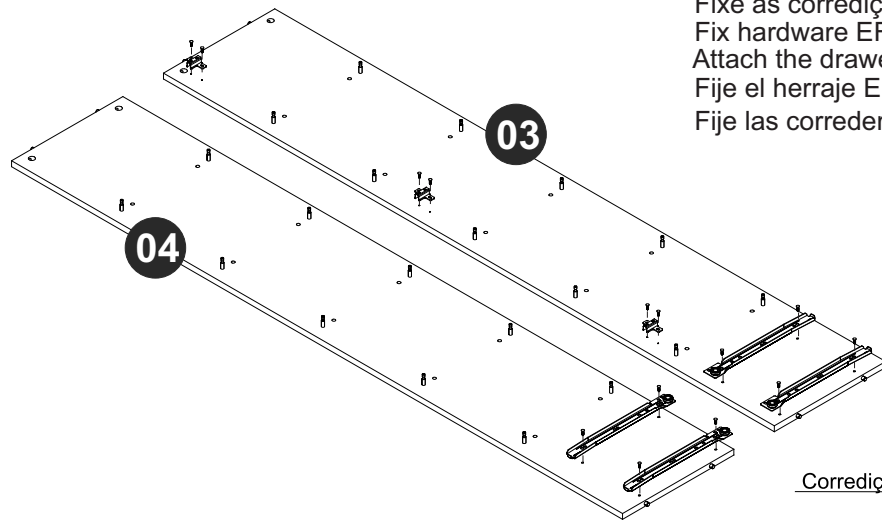

Correção/Corredera/Drawer tracks

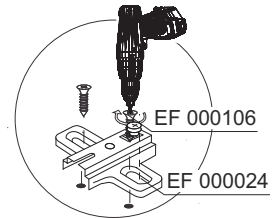
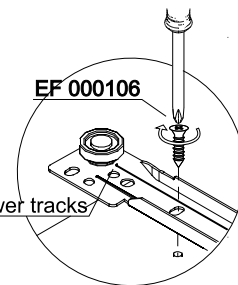

PASSO 4 / STEP 4/ PASO 4

Fixe o puxador e a ferragem EF 000044 usando a ferragem EF 000106 na peça 06.
Fix the handle and the hardware EF 000044 using hardware EF 000106 to piece 06.
Fije la manija y el herraje EF 000044 utilizando el herraje EF 000106 en la pieza 06.

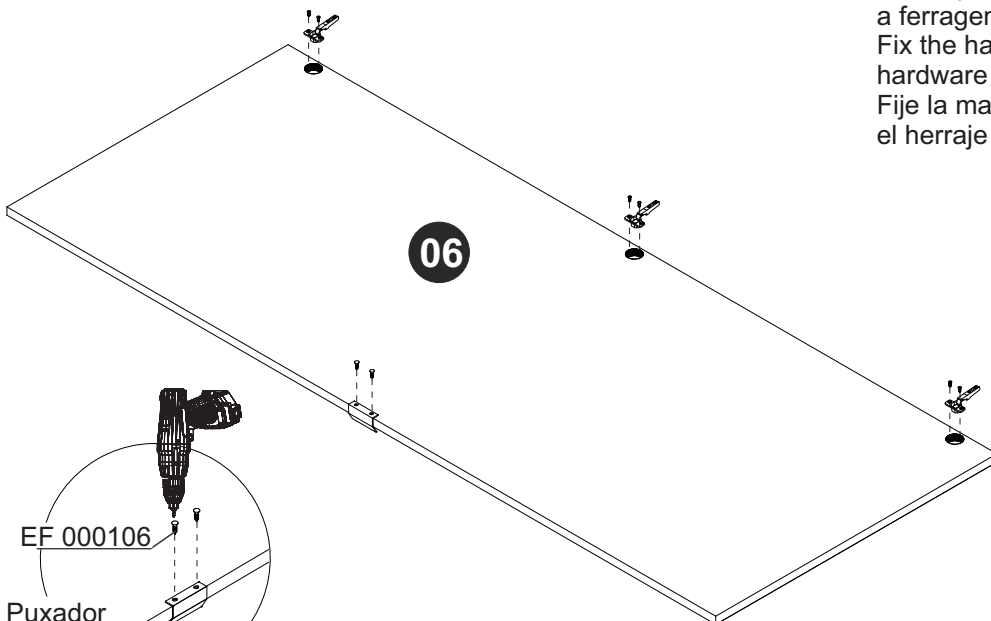

EF 000106

Puxador
Handle
Manija

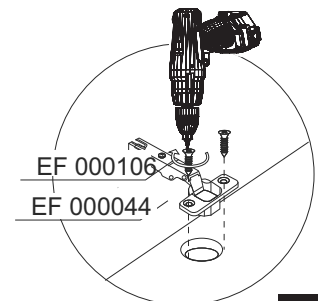

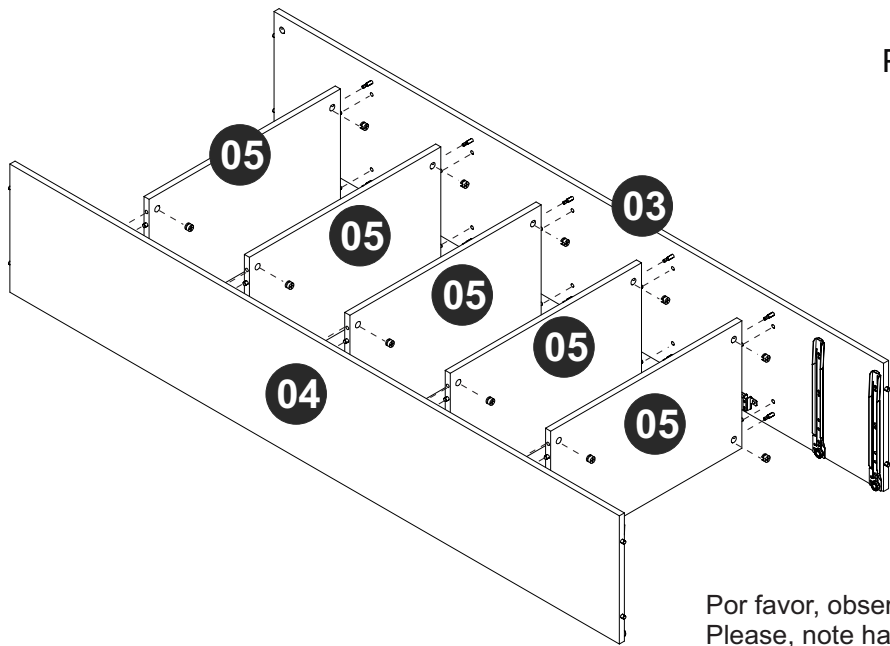

PASSO 5 / STEP 5 / PASO 5

Conecte as peças 03, 04 e 05, insira a ferragem EF 000216 e gire para apertar.
 Connect pieces 03, 04 and 05, insert hardware EF 000216 and turn to tighten.
 Junte las piezas 03, 04 y 05, añáde el herraje EF 000216 y gire para apretar.

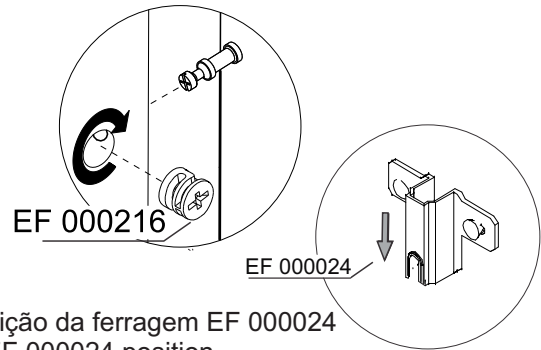

Por favor, observe a posição da ferragem EF 000024
 Please, note hardware EF 000024 position.
 Por favor, observe la posición del herraje EF000024.

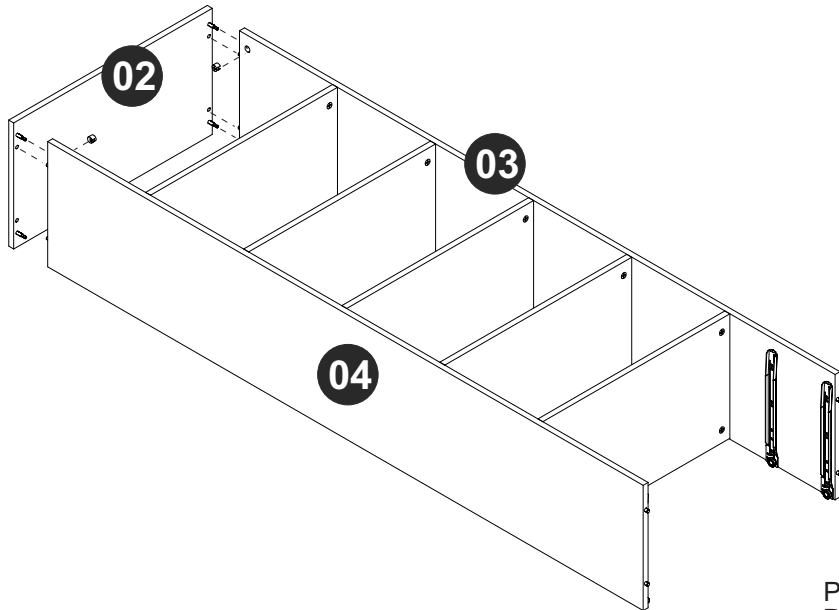

PASSO 6 / STEP 6 / PASO 6

Conecte a peça 02, insira a ferragem EF 000216 e gire para apertar.
 Connect piece 02, insert hardware EF 000216 and turn to tighten.
 Junte la pieza 02, añáde el herraje EF 000216 y gire para apretar.

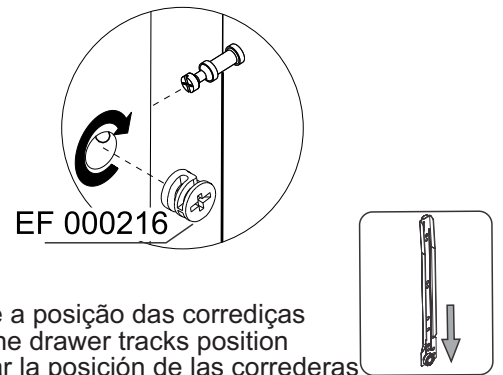

Por favor, note a posição das corredeiras
 Please, note the drawer tracks position
 Por favor, notar la posición de las correderas

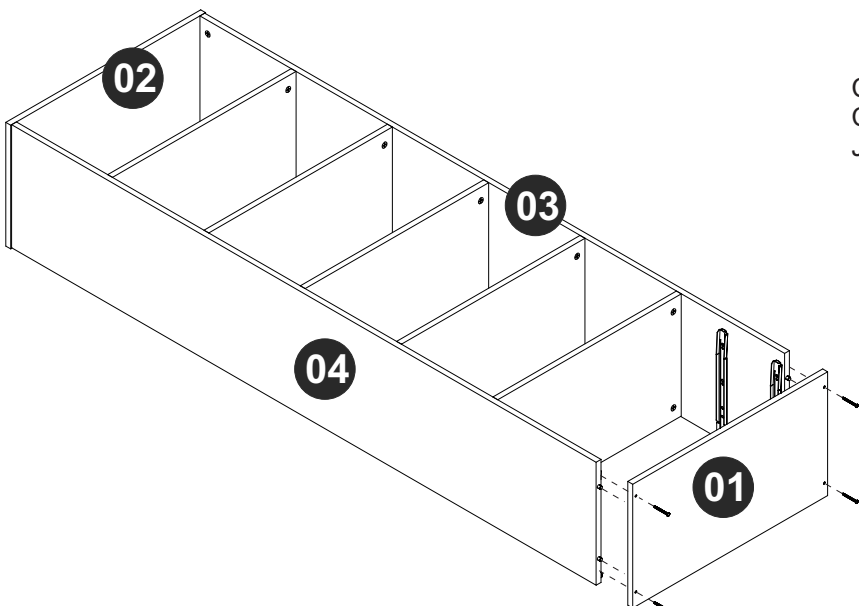

PASSO 7 / STEP 7 / PASO 7

Conecte a peça 01 utilizando a ferragem EF 000132.
 Connect piece 01 using hardware EF 000132.
 Junte la pieza 01 utilizando el herraje EF 000132.

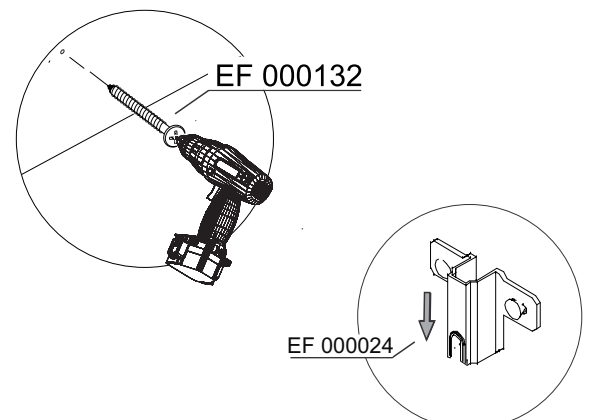

Por favor, observe a posição da ferragem EF 000024
 Please, note hardware EF 000024 position.
 Por favor, observe la posición del herraje EF000024.

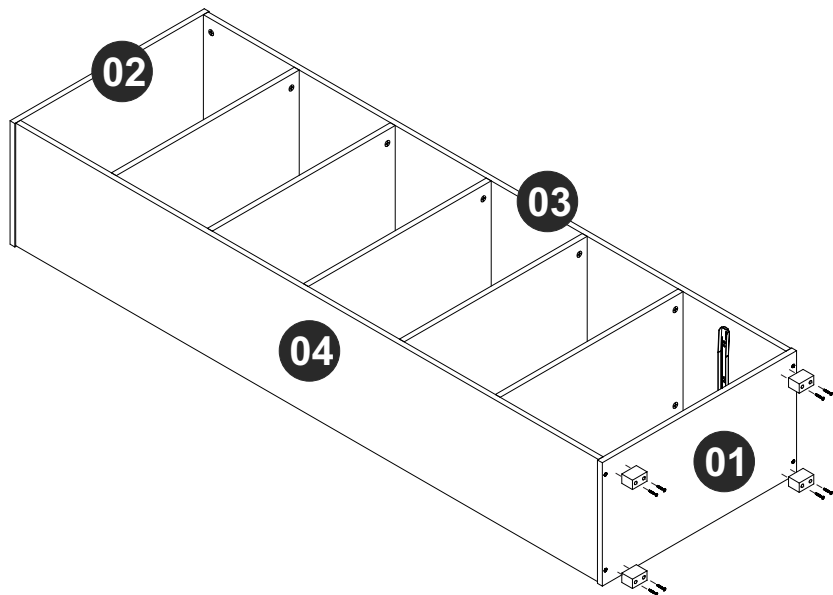

PASSO 8 / STEP 8/ PASO 8

Utilize a ferragem EF 000381 para fixar os pés.
 Use hardware EF 000381 to attach the feet.
 Utilice el herraje EF 000381 para fijar los pies.

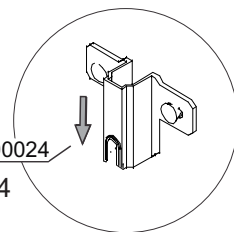
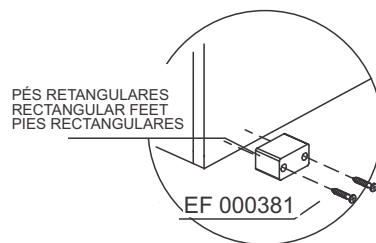

Por favor, observe a posição da ferragem EF 000024
 Please, note hardware EF 000024 position.
 Por favor, observe la posición del herraje EF000024.

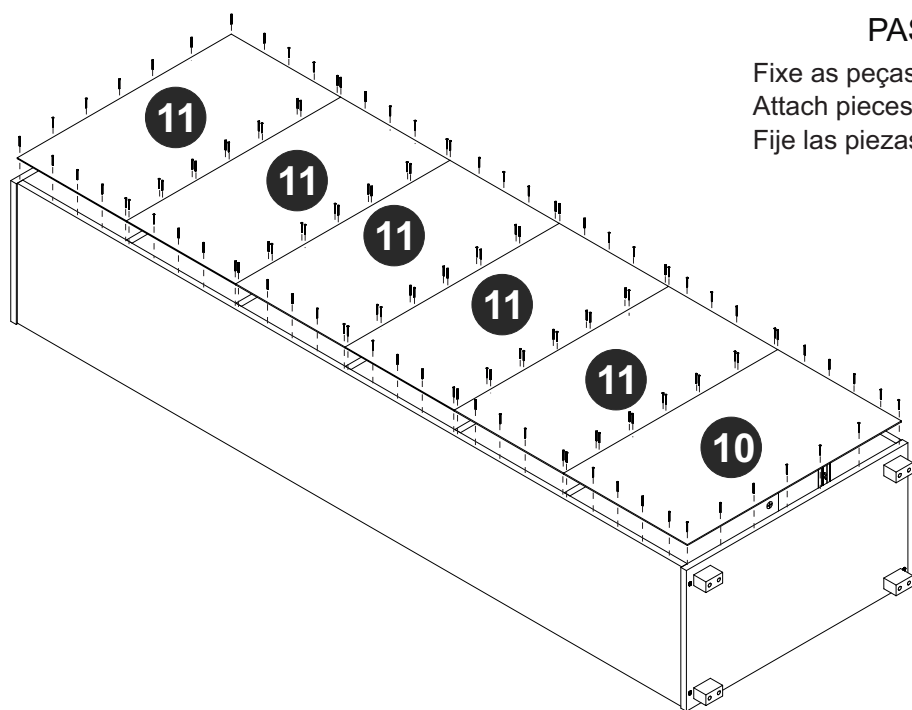

PASSO 9 / STEP 9 / PASO 9

Fixe as peças 10 e 11 ao móvel utilizando a ferragem EF 000168.
 Attach pieces 10 and 11 at the furniture using hardware EF 000168.
 Fije las piezas 10 y 11 al mueble utilizando el herraje EF 000168.

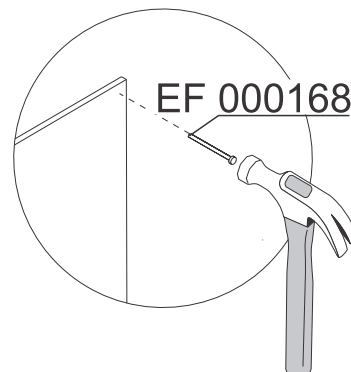

PASSO 10 / STEP 10 / PASO 10

Conecte as peças 20, 21 e 22, insira a ferragem EF 000216 e gire para apertar.
 Connect pieces 20, 21 and 22 insert hardware EF 000216 and turn to tighten.
 Junte las piezas 20, 21 y 22, añada el herraje EF 000216 y gire para apretar.

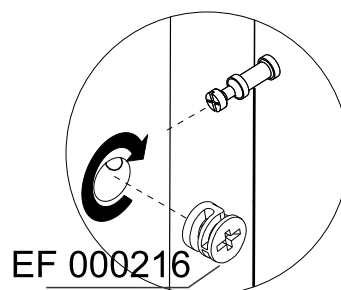
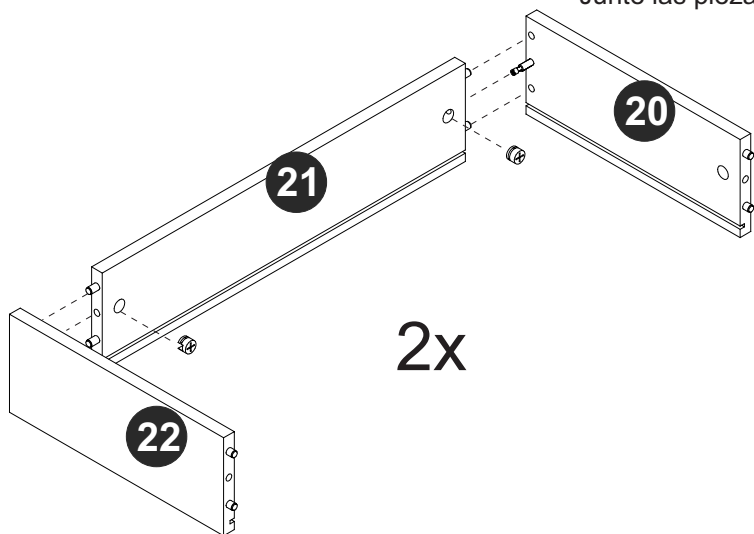

PASSO 11 / STEP 11/ PASO 11

Encaixe a peça 09 entre os espaços específicos.
Fix piece 09 through the specific space.
Fije la pieza 09 entre los espacios específicos.

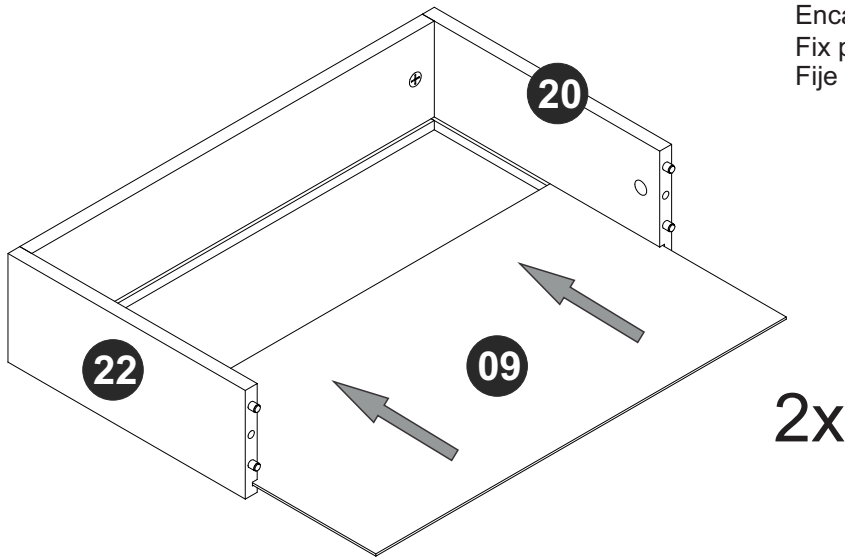

PASSO 12 / STEP 12 / PASO 12

Conecte as peças 07, 20 e 22, insira a ferragem EF 000216 e gire para apertar. Fixe o puxador utilizando a ferragem EF 000106.
Connect pieces 07, 20 and 22 insert hardware EF 000216 and turn to tighten. Attach the handle using hardware EF 000106.
Junte las piezas 07, 20 y 22 añade el herraje EF 000216 y gire para apretar. Fije la manija utilizando el herraje EF 000106.

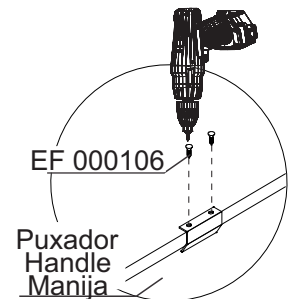
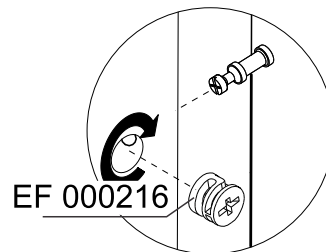
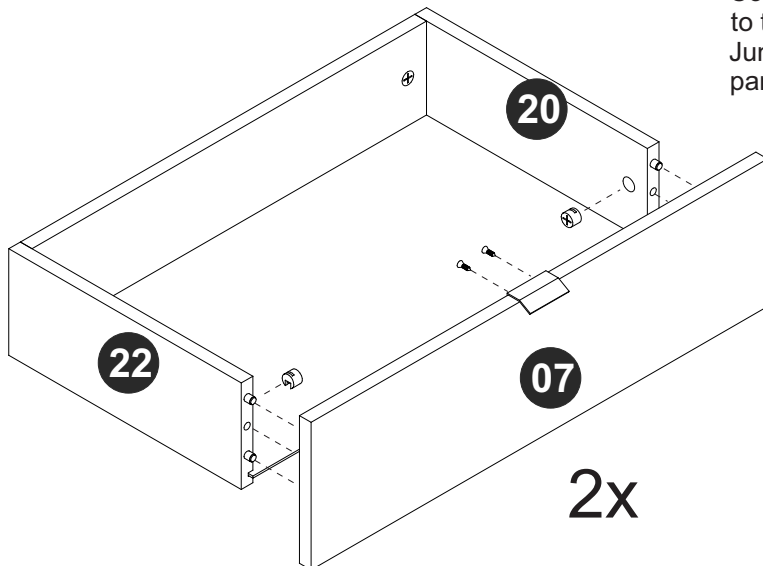

PASSO 13 / STEP 13 / PASO 13

Fixe as corrediças utilizando a ferragem EF 000106.
Attach the drawer tracks using hardware EF 000106.
Fije las correderas utilizando el herraje EF 000106.

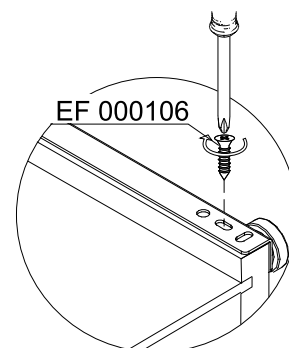
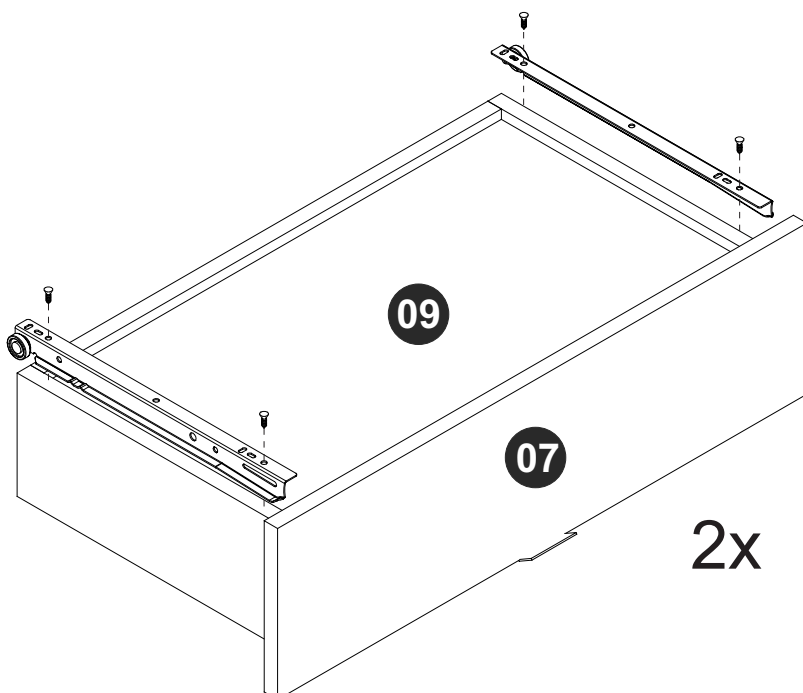

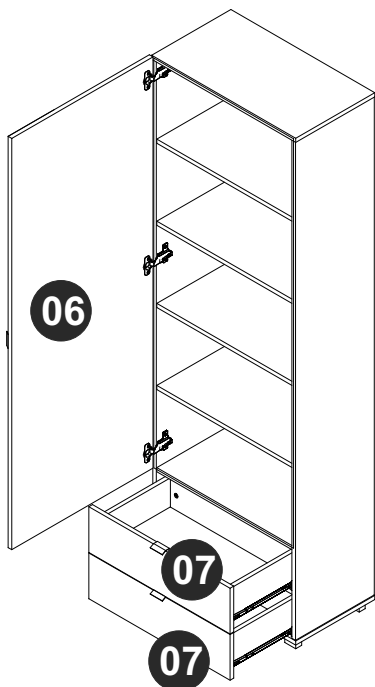

PASSO 14 / STEP 14 PASO 14

Fixe a peça 06 ao móvel .
 Fix piece 06 at the furniture.
 Fije la pieza 06 al mueble.

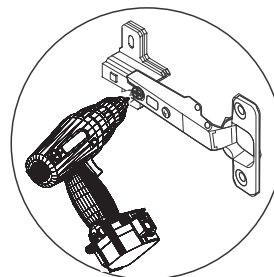

PASSO 15 / STEP 15 / PASO 15

Use o parafuso EF 000248 para fixar a ferragem EF 000529 ao móvel.
 Use hardware EF 000248 to fix the hardware EF 000529 at the furniture.
 Utilice el herraje EF 000248 para fijar el herraje EF000529 al mueble.

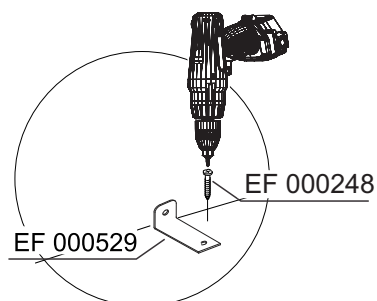
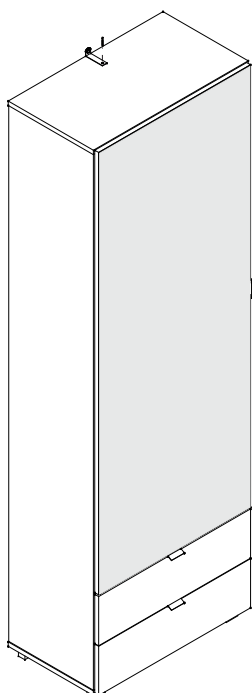

PASSO 16 / STEP 16 / PASO 16

Use as ferragens EF 000246 e EF 000016 para fixar o móvel na parede.
 Use hardware EF 000246 and EF 000016 for fixing the furniture on the wall.
 Utilice los herrajes EF000246 y EF000016 para fijar el mueble en la pared.

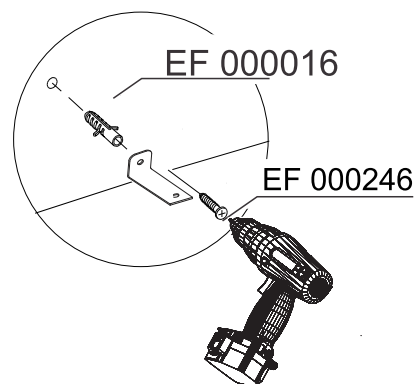
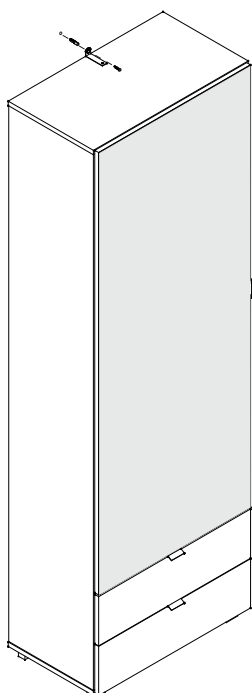

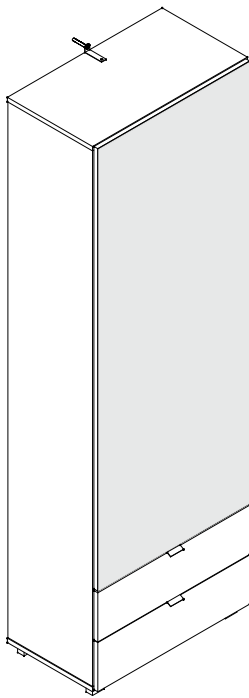

PASSO 17 / STEP 17 / PASO 17

Utilize o tapa furos para cobrir os parafusos aparentes.
Use the sticker to cover the apparent screws.
Utilice los tapa huecos para cubrir los tornillos aparentes.

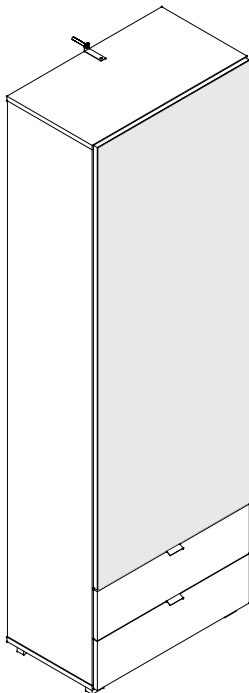
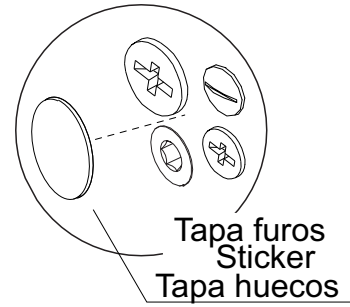

PASSO 18 / STEP 18 / PASO 18

Utilize o giz para dar o acabamento final ao produto.
Use the chalk to give the final finish on the product.
Utilize la tiza para dar el acabado final al producto.

